

Svetlana 4CX5000R/8170W Radial Beam Power Tetrode



The Svetlana™ 4CX5000R/8170W is designed for audio and radio frequency applications. The Svetlana 4CX5000R/8170W has a directly-heated thoriated tungsten mesh filament for mechanical ruggedness to withstand the shock and vibration encountered in military applications.

The Svetlana 4CX5000R/8170W is manufactured in the Svetlana factory in St. Petersburg, Russia, and is designed to be a direct replacement for the 4CX5000R/8170W manufactured in the United States.



Svetlana 4CX5000R/8170W

General Characteristics

Electrical

Filament:	Thoriated tungsten mesh
Voltage	$7.5 \pm 0.37V$
Current, at 7.5 Volts	75A
Amplification factor (average):	
Grid to screen	4.5
Direct interelectrode capacitances (grounded filament):	
C _{in}	122 pF
C _{out}	23 pF
C _{gp}	1.0 pF
Direct interelectrode capacitances (grounded grid):	
C _{in}	58 pF
C _{out}	23 pF
C _{pk}	0.16 pF
Maximum frequency for full ratings (CW)	110 MHz

Mechanical

Maximum overall dimensions:	
Length	23.18 cm (9.13 in.)
Diameter	12.54 cm (4.94 in.)
Net weight	4.3 kg (9.5 lb)
Operating position	Axis vertical, base up or down
Maximum operating temperature, ceramic/metal seals or envelope	250° C
Cooling	Forced air
Base	Coaxial, designed for use with SK300 series sockets
Chimney	SK306 or SK356

Radio Frequency Power Amplifier Class C FM

Absolute maximum ratings

DC plate voltage	7500V
DC screen voltage	1500 V
DC grid voltage	-500 V
DC plate current	3.0 A
Plate dissipation	5 kW
Screen dissipation	250 W
Grid dissipation	75 W

Typical Operation

(Frequencies to 110 MHz)	
DC plate voltage	6500 V
DC screen voltage	750 V
DC grid voltage	-350 V
DC plate current	2.3 A
DC screen current*	0.2 A
DC grid current*	0.05 A
Measured driving power	100 W
Useful output power	10 kW

* Approximate values

Radial Beam Power Tetrode

Plate Modulated RF Power Amplifier, Grid Driven, Class C Telephony

Carrier Conditions

Absolute maximum ratings

DC plate voltage	5500 V
DC screen voltage	1000 V
DC grid voltage	-500 V
DC plate current	2.5 A
Plate dissipation	3.5 kW
Screen dissipation	250 W
Grid dissipation	75 W

Typical Operation

DC plate voltage	5000 V
DC screen voltage	500 V
Peak AF screen voltage (100% mod.)	450 V
DC grid bias voltage	-400 V
DC plate current	1.4 A
DC screen current*	0.26 A
DC grid current*	0.05 A
Peak rf grid voltage*	520 V
Grid driving power (calculated)	25 W
Plate dissipation	1100 W
Plate output power	5800 W

Audio Frequency Power Amplifier or Modulator, Grid Driven, Class AB₁

Absolute maximum ratings

DC plate voltage	7500 V
DC screen voltage	1500 V
DC plate current	4.0 A
Plate dissipation	6000 W
Screen dissipation	250 W
Grid dissipation	75 W

Typical Operation (two tubes, sinusoidal waveform)

DC plate voltage	5000	7000 V
DC screen voltage	1250	1250 V
DC grid voltage**	-280	-325 V
Zero-signal plate current	1.0	0.70 A
Maximum signal plate current	4.40	3.65 A
Maximum signal screen current*	0.33	0.24 A
Peak AF grid voltage	240	235 V
Driving power	0	0 W
Load resistance plate-to-plate	2370	4100 Ohms
Maximum signal plate dissipation	4200	4200 W
Plate output power	13.5	17.5 kW

* Approximate values ** Adjust for specified zero-signal plate current

Svetlana 4CX5000R/8170W

RF Linear Amplifier, Grid Driven, Class- AB₁

Absolute Maximum Ratings

DC plate voltage	7500 V
DC screen voltage	1600 V
DC plate current	4.0 A
Plate dissipation	6000 W
Screen dissipation	250 W
Grid dissipation	75 W

Typical Operation (Frequencies to 110 MHz)

DC plate voltage	7500 V
DC screen voltage	1250 V
DC grid voltage**	-300 V
Zero-signal DC plate current	0.5 A
Single-tone DC plate current	1.90 A
Single-tone DC screen current*	0.20 A
Peak RF grid voltage*	300 V
Plate dissipation	4200 W
Single-tone plate output power	10 kW

* Approximate values ** Adjust for specified zero-signal plate current

Electrical Application

Plate operation The rated maximum plate dissipation of the tube is 6 kilowatts for Class AB and Class B applications. This power may be safely sustained with adequate air cooling. The tube must be protected from damage which may be caused by an internal arc occurring at high plate voltage. A protective resistance should always be connected in series with each tube anode to help absorb power-supply stored energy if an internal arc should occur.

Control-grid operation The maximum control grid dissipation is 75 Watts, determined (approximately) by the product of the dc grid current and the peak positive grid voltage.

Screen-grid operation The maximum screen grid dissipation is 250 Watts. With no ac applied to the screen grid, dissipation is the product of dc screen voltage and the dc screen current. Plate voltage, plate loading or bias voltage must never be removed while filament and screen voltages are present.

Filament operation Svetlana recommends that a new tube, or a tube which has been in storage for some period of time, be operated with only filament voltage applied for a period of from 30 to 60 minutes before full operation begins. Once normal operation has been established, a minimum filament warm-up time of four to five seconds is sufficient for full filament emission. Filament voltage should be measured at the socket.

At rated nominal filament voltage, the peak emission capability of the tube is many times that needed for communication service. A reduction in filament voltage will lower the filament temperature, and this reduction will substantially increase life expectancy. The correct value of filament voltage should be determined for the particular application. Svetlana recommends that the tube be operated at full nominal voltage for an initial stabilization period of 100 to 200 hours before any action is taken to operate at reduced voltage. The voltage should gradually be reduced until there is a slight degradation in performance—such as power output or distortion. The voltage should then be increased a few tenths of a Volt above the value where performance degradation was first noted. The operating point should be rechecked after 24 hours.

Radial Beam Power Tetrode

Svetlana 4CX5000R/8170W Outline Drawing

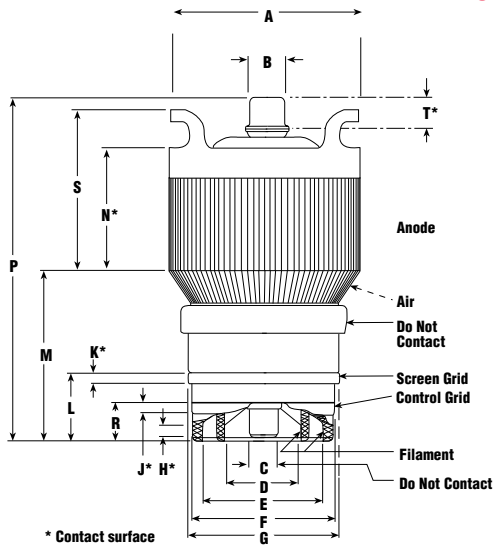

Mechanical Application

Mounting The Svetlana 4CX5000R/8170W must be mounted vertically, base up or down. The tube is rated for shock and vibration as encountered in military applications.

Storage If the 4CX5000R/8170W is to be stored as a spare, it should be kept in its original packaging to minimize the possibility of handling damage.

Cooling The 4CX5000R/8170W requires forced-air cooling in all applications. The tube socket should be mounted in a pressurized compartment so that the cooling air passes through the socket and is guided to the anode cooling fins by an air chimney. If cooling air is not passed around the base of the tube and through the socket, arrangements must be made to assure adequate cooling of the tube base and socket contacts.

Adequate movement of cooling air around the base of the tube keeps the tube base and the socket contact fingers at safe operating temperatures.

Although the maximum temperature rating for seals and the anode core is 250° C, good engineering practice requires that a safety factor be allowed. The table shows cooling parameters with the cooling air at 50° C and maximum tube anode temperature of 200° C. The figures are for the tube with air passing in a base-to-anode direction. Pressure drop values shown are approximate and are for the tube/socket/chimney combination.

Dimensional Data

Dim.	Millimeters		Inches	
	Min.	Max.	Min.	Max.
A	122.22	125.43	4.812	4.938
B	21.72	22.73	0.855	0.895
C	18.29	19.30	0.720	0.760
D	48.16	49.17	1.896	1.936
E	79.58	80.59	3.133	3.173
F	96.32	97.33	3.792	3.832
G	101.09	102.11	3.980	4.020
H	4.78	—	0.188	—
J	4.78	—	0.188	—
K	4.78	—	0.188	—
L	44.81	46.38	1.764	1.826
M	106.38	115.90	4.188	4.563
N	73.03	82.55	2.875	3.250
P	219.08	231.78	8.625	9.125
R	25.04	26.67	0.986	1.050
S	98.43	107.95	3.875	4.250
T	9.53	—	0.375	—

Minimum Cooling Air-Flow Requirements

Sea Level		
Plate dissipation (Watts)	Air flow (CFM)	Pressure drop (Inches of water)
2000	75	0.4
4000	145	1.1
6000	230	2.0

At altitudes significantly above sea level, the flow rate must be increased for equivalent cooling. At 5,000 feet above sea level, both the flow rate and the pressure drop should be increased by a factor of 1.20, while at 10,000 feet both flow rate and pressure drop must be increased by 1.46.

Special applications If the user needs to operate this tube under conditions widely different from those given in this publication, contact any location of Svetlana Electron Devices for technical assistance.

Svetlana 4CX5000R/8170W

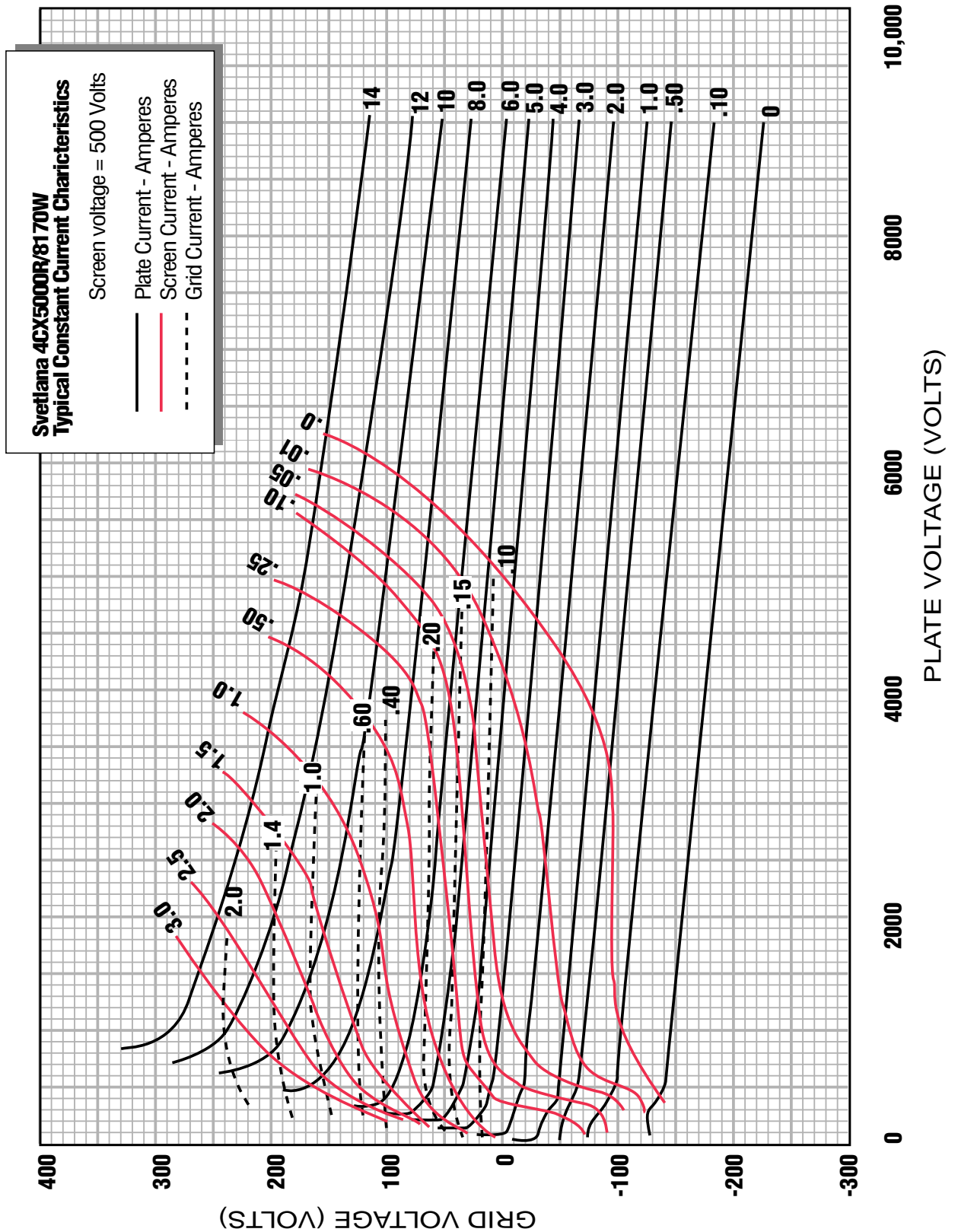

Radial Beam Power Tetrode

